

# NAPU®

## NAPU®

Since 2005, the founding team of Napu Compressors has been committed to the research and development of dry oil-free twin-screw technology. Over the past 20 years, through extensive in-depth research and experiments, the founding team has continuously overcome one technical difficulty after another. From formulating technical specifications for the manufacturing of dry oil-free twin-screw airends, including asymmetric profiles, casings with cooling jackets, and spiral labyrinth seals, to establishing relevant standards for the drive and control of the entire dry oil-free twin-screw system, compressed air flow channels, cooling and lubrication, and noise suppression, the team has fundamentally and comprehensively mastered the dry oil-free twin-screw compression technology and manufacturing processes. Moreover, it has surpassed most internationally renowned brands in terms of design concepts and manufacturing quality.

Napu dry oil-free twin-screw air compressors are widely used in electronics and semiconductors, food and beverages, biotechnology and pharmaceuticals, energy and chemicals, and high-end manufacturing industries. They have gained high recognition from users due to their reliable quality and long-term warranty commitment. With the vision of continuously providing users with improved productivity, Napu Compressors looks forward to cooperating with you!



**Semiconductor and  
New Materials Industry**

***Special-purpose  
oil-free screw compressor***

**Shanghai NAPU Compressor Technology Co. Ltd.**

📍 No.3238 Huhang Highway, Fengxian District, Shanghai, China 🌐 [napucompressor.com](http://napucompressor.com)  
✉ [info@napucompressor.com](mailto:info@napucompressor.com) ☎ 021 - 58387871 13701958840

## 100% CERTIFIED OIL-FREE AIR

NAPU is committed to designing and manufacturing the most durable oil-free screw compressors. The fully oil-free OF series screw compressors embody this requirement. It is an ideal choice for industries with strict requirements for high-quality oil-free air, providing the highest reliability, safety and extremely low energy costs.



Oil-free air is used in various industries where air quality is crucial to final products and production processes, including food and beverage, pharmaceuticals, petrochemicals, semiconductors and electronic products, medical care, automotive spraying, textiles, etc. In these stringent application scenarios, even tiny amounts of oil contamination can be sufficient to cause production shutdowns or product damage.

### Oil Free Air Technology

In the past 10 years, NAPU has invest majority business resources to develop oil-free air technology, resulting in a range of air compressors and blowers that provide 100% pure, clean air. Through continuous research and development, NAPU achieved a new milestone, setting the standard for air purity as the first manufacturer to be awarded CLASS 0 certification.

### Eliminating any risk

As the industry leader committed to meeting the needs of the most demanding customers, Atlas Copco requested the renowned TÜV institute to type-test its range of oil-free compressors and blowers. Using the most rigorous testing methodologies available, all possible oil forms were measured across a range of temperatures and pressures. The TÜV found no traces of oil at all in the output air stream.



CLASS	oil content (particles, liquid, vapor) mg/m <sup>3</sup>
0	As specified by the equipment user or supplier and more stringent than class 1
1	<0.01
2	<0.1
3	<1
4	<5

Current ISO 8573-1 (2010) classes (the five main classes and the associated maximum concentration in total oil content).



### Solar Photovoltaic Materials

- Provides 100% pure, oil-free air for a variety of applications.
- Compliant with the ISO 8573-1 CLASS 0 certification standard, it makes no compromises whatsoever on the resulting purity, ensuring zero risk of contamination.

### Battery Cathode Materials

- It is extremely important to generate clean, dry, and high-quality air with optimal energy efficiency.
- Applications include removing tiny impurities from material surfaces.

### Battery Anode Materials

- Certified 100% oil-free and reliable compressed air is crucial for maintaining continuous production operations.
- With the ability to operate under extreme temperature and humidity conditions, high performance and reliability are essential.

### Electrolyte

- 100% oil-free air is crucial for preventing process contamination.
- CLASS 0 eliminates all risks, maintaining the high quality of products and the professional reputation of the brand.

### Separator

- The lowest energy cost, accounting for up to 80% of the total lifecycle cost of the compressor.
- With innovative single-stage screw compression technology, it minimizes downtime and reduces maintenance costs.

### Semiconductor Materials and Manufacturing

- Pure protective gas is extremely important for the purification and processing of semiconductor materials.
- 100% certified Class 0 oil-free gas ensures the highest gas quality.
- The energy consumption required for continuous operation is extremely low.

### Chip Packaging and Testing

- The lowest energy cost accounts for up to 80% of the compressor's total lifecycle cost.
- Leveraging innovative dry screw oil-free compression technology, it minimizes downtime and reduces maintenance costs, while offering a wide range of flow rates and pressures.

### PCB (Printed Circuit Board)

- Improve energy efficiency and productivity while reducing environmental impact.
- Leveraging innovative low-pressure dry oil-free screw compression technology, it minimizes downtime and lowers maintenance costs.





## Air Ends

- The unique profile design ensures the working efficiency and sealing of the compression
- Aviation type impeller coating ensures high durability
- The rotor section is made of high tensile, strength steel
- Cooling jackets is used for complete air end
- Seals are made of reusable high-quality alloys



## Airflow Duct

- All cast iron material, inner wall coating, optimal noise reduction design.
- High pressure outlet cast iron three-in-one integrated design with venturi, exhaust and discharge channels.
- Exhaust muffler made of cast iron, integrated design, built-in muffler material and check valve.
- Full flange connection, reliable sealing and quick maintenance.

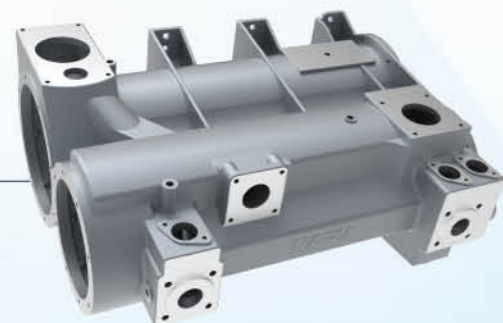

## Cooler

- Integrated design, compact and robust
- Spiral design of water flow, high heat exchange efficiency
- Easy to switch with integrated heat recovery module
- Built-in flow channel, simple and reliable

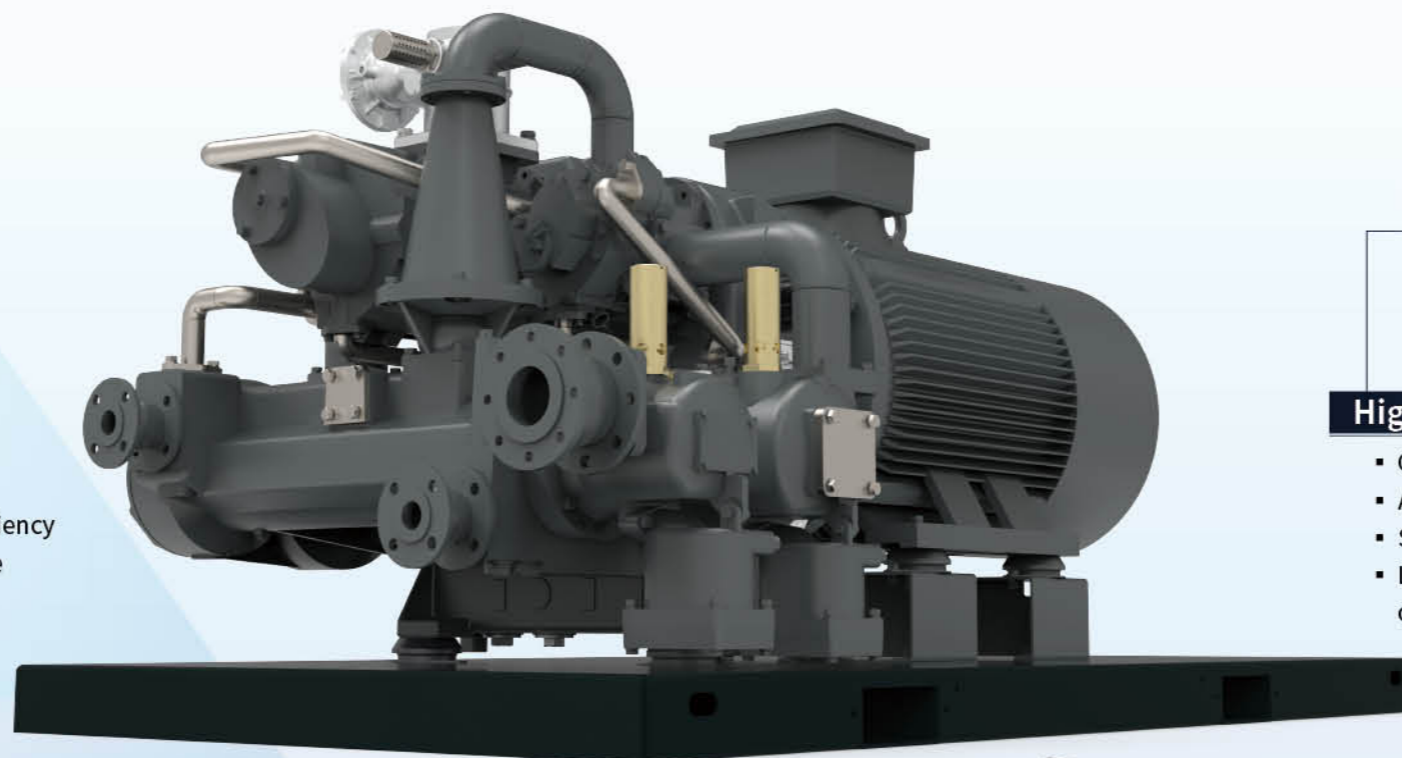

## High Efficiency Cooler and Water Separator

- Corrosion-resistant material, long shell life
- Advanced welding procedure ensures reliable sealing.
- Star shaped fin design increasing the heat exchange area
- Labyrinth water separator effectively separates the condensed water



## Electrical Motor

- High-end international brand motors and electrical components
- Industry's highest safety and efficiency standards



## High Efficiency Oil-Free Compressor Aired

- The unique profile design ensures the working efficiency and sealing.
- Aviation type impeller coating ensures high durability
- The rotor section is made of high tensile, strength steel
- Cooling jackets is used for complete air end



### Main Vent Pre-positioned Gas-Water Separator

- The compressed air is cooled before venting.
- Prevent high-temperature gas from being discharged into the cabinet.
- Prior to venting, the compressed air flows through a gas-water separator, which discharges condensed water out of the pipeline.



### Rotor Screw

- Corrosion-resistant material, long life
- Precise machining, rotor cutting grinding before measuring Coating PTFE fits working condition oil free
- High efficiency compressing



### Integrated Muffler/Check Valve

- The high-pressure head outlet is designed with an integrated muffler and check valve.
- High-quality cast gray iron is used for the shell, with stainless steel filling.
- It features an integrated built-in stainless steel check valve and an integrated valve core.
- The vent pipe interface is made of cast material.



### High-Voltage Motor

- The compressed air is cooled before venting.
- Prevent high-temperature gas from being discharged into the cabinet.
- Prior to venting, the compressed air flows through a gas-water separator, which discharges condensed water out of the pipeline.

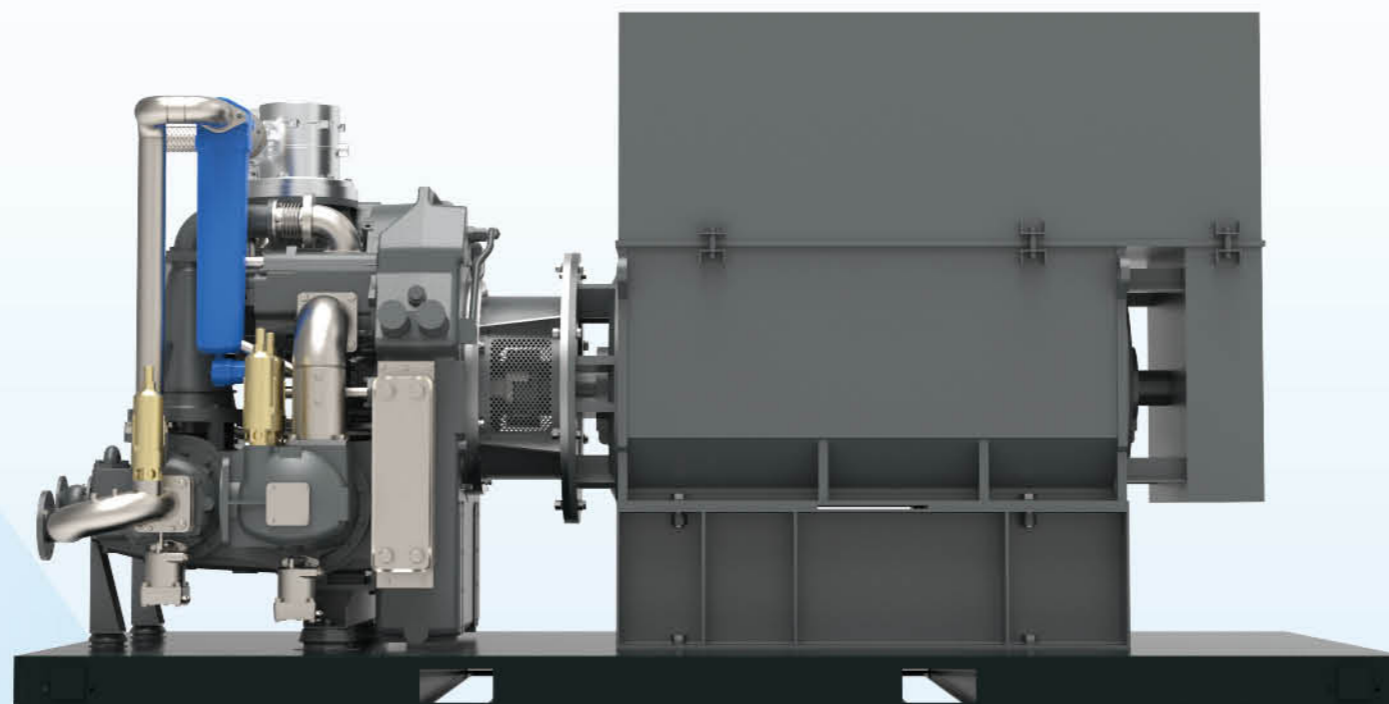

### High-Efficiency Oil Cooler

- It is installed as a whole, closely attached to the oil tank to reduce pipelines.
- Cooling water enters the oil cooler directly through the oil tank.
- Made of 316L stainless steel with brazing technology, it features high pressure resistance and corrosion resistance.
- It is equipped with built-in detection points for oil pressure, water pressure, oil temperature, and water temperature, assisting in fault diagnosis.



### Coupling

- It features a robust and compact structure, facilitating maintenance and disassembly.
- Long service life design: Elastic diaphragms rarely need replacement.
- User-friendly maintenance design.
- No subsequent replacement of spare parts, resulting in no replacement costs.



**Stainless Steel Pre-cooler**

- Both the intercooler and aftercooler adopt a pre-cooler design,
- which effectively reduces the heat load of the main cooler and improves heat exchange efficiency,
- thereby greatly extending the service life of the main cooler.
- The pre-cooler features a stainless steel outer fin structure to enhance heat exchange efficiency.

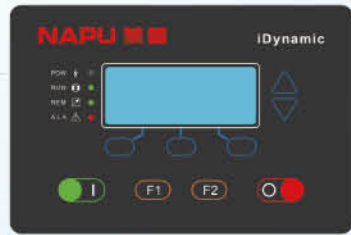

**i Dynamic**

- Controls the main drive motor and regulates system pressure to maximize energy efficiency.



**Muffler**

- The muffler designed at the head outlet reduces noise.
- It uses cast iron, an optimal sound-absorbing material.
- Combined with a stainless steel compensator, it isolates vibrations.
- The design of the high-pressure head outlet muffler effectively optimizes the venting channel and minimizes venting noise.

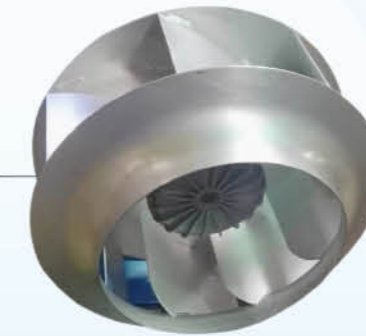

**Centrifugal Fan**

- Compact design with large air volume and higher air pressure
- High energy and low consumption.
- Low noise level and maintenance free

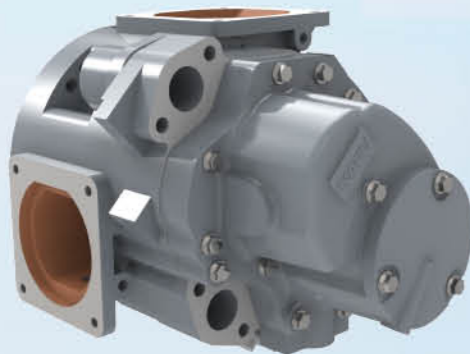

**High Efficiency Oil-Free Compressor Airend**

- The unique profile design ensures the working efficiency and sealing.
- Aviation type impeller coating ensures high durability
- The rotor section is made of high tensile, strength steel
- Cooling jackets is used for complete air end

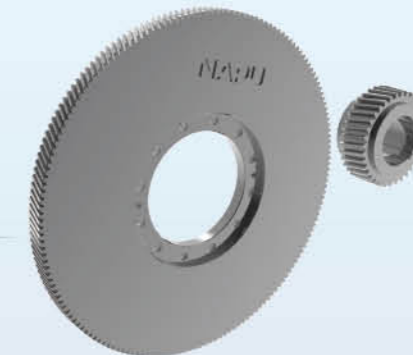

**Gear Set**

- DIN/AGMAQB manufacturing standard
- Efficient and robust, designed for 30 years of use
- Low vibration, low noise level

**power frequency**

Model	Nominal Flow Rate ( M <sup>3</sup> /min )			Install Power ( kw )	Noise Level ( db )	Weight ( KG )	
	7bar	8.5bar	10bar			Water Cooled Type	Air Cooled Type
OFA15	2.4	2.1	1.8	15	74	-	1 030
OFA22	3.7	3.2	2.7	22	74	-	1 070
OFA30	4.8	4.4	4.0	30	74	-	1 300
OFA37	5.9	5.3	5.0	37	74	-	1 355
OFA45	7.0	6.5	6.1	45	74	-	1 390
OFA55	9.2	7.9	7.3	55	74	-	1 860
OFA75	12.2	11.2	10.7	75	74	-	1 935
OFA90	14.7	13.5	12.7	90	74	-	2 000
OFA110	19.3	17.2	16.0	110	74	-	3 660
OFA132	22.9	19.5	18.8	132	74	-	3 700
OFA160	29.4	25.7	23.8	160	74	-	4 150
OFA200	36.6	33.1	30.4	200	74	-	4 230
OFA250	44.5	41.0	37.4	250	74	-	4 300
OFA275	47.4	43.0	41.0	275	74	-	4 500
OFA315	51.5	47.6	46.0	315	74	-	6 200
OFA355	56.3	52.6	50.4	355	74	-	6 500
OFW37	5.9	5.3	5.0	37	74	1 355	-
OFW45	7.0	6.5	6.1	45	74	1 450	-
OFW55	8.8	7.9	7.3	55	74	1 800	-
OFW75	11.9	11.2	10.7	75	74	1 850	-
OFW90	14.3	13.5	12.7	90	74	1 925	-
OFW110	19.1	17.1	16.0	110	74	2 635	-
OFW132	21.9	19.6	18.9	132	74	2 760	-
OFW160	28.3	26.1	24.2	160	74	3 850	-
OFW200	36.1	33.1	30.4	200	74	4 000	-
OFW250	43.1	41.0	37.0	250	74	4 100	-
OFW275	46.4	43.0	41.0	275	74	4 300	-
OFW315	50.9	47.6	46.0	315	74	6 550	-
OFW355	56.3	52.6	50.4	355	74	6 950	-
OFW400	62.1	57.8	55.8	400	74	7 050	-
OFW450	76.5	71.5	63.8	450	74	8 400	-
OFW500	83.9	78.3	73.1	500	74	8 400	-
OFW630	102.9	95.7	89.0	630	74	9 125	-
OFW750	122.8	109.6	101.8	750	74	9 225	-

**frequency conversion**

Model	Nominal Flow Rate ( M <sup>3</sup> /min )	Install Power ( kw )	Noise Level ( db )	Weight ( KG )	
				Water Cooled Type	Air Cooled Type
OFA15VSD	1.1 – 3.3	15	74	-	930
OFA22VSD	4.5 – 5.6	22	74	-	1 150
OFA30VSD	4 – 6.6	30	74	-	1 300
OFA37VSD	5 – 8.4	37	74	-	1 600
OFA45VSD	6.1 – 11.1	45	74	-	1 750
OFA55VSD	7.3 – 9.4	55	74	-	1 900
OFA75VSD	10.7 – 12.4	75	74	-	2 630
OFA90VSD	12.7 – 15.4	90	74	-	2 700
OFA110VSD	16.0 – 19.5	110	74	-	3 750
OFA132VSD	18.8 – 21.8	132	74	-	4 300
OFA160VSD	24.0 – 29.6	160	74	-	4 700
OFA200VSD	12.2 – 36.6	200	74	-	5 600
OFA250VSD	14.2 – 41.8	250	74	-	5 850
OFA275VSD	15.8 – 47.4	275	74	-	6 350
OFA315VSD	45.0 – 52.1	315	74	-	6 750
OFA355VSD	50.4 – 57.5	355	74	-	6 950
OFW37VSD	2 – 5.9	37	74	1 750	-
OFW45VSD	2.3 – 7	45	74	1 950	-
OFW55VSD	4.5 – 8.8	55	74	2 080	-
OFW75VSD	4.5 – 13.2	75	74	2 170	-
OFW90VSD	4.5 – 15.5	90	74	2 220	-
OFW110VSD	6.4 – 19.1	110	74	2 700	-
OFW132VSD	7.7 – 22.4	132	74	3 500	-
OFW160VSD	14.5 – 42.9	160	74	3 750	-
OFW200VSD	15.2 – 36.1	200	74	4 150	-
OFW250VSD	16.3 – 43.5	250	74	4 850	-
OFW275VSD	16.3 – 46.4	275	74	5 400	-
OFW315VSD	17.6 – 50.9	315	74	6 650	-
OFW355VSD	18.9 – 56.3	355	74	6 950	-
OFW400VSD	19.3 – 62.1	400	74	7 060	-
OFW450VSD	25.7 – 76.5	450	74	8 400	-
OFW500VSD	28.5 – 83.9	500	74	8 400	-
OFW630VSD	33.6 – 102.9	630	74	9 125	-
OFW750VSD	42.4 – 122.8	750	74	9 225	-