

NAPU[®]

The founder led his team and launched an after-sales service company specialised in oil-free rotary screw air compressors in 2005, offering a range of products from air ends to compressors of leading brands. With previous experience in manufacturing oil-free air compressors, the founder established a workshop in Shanghai in 2009 specialised in manufacturing oil-free air ends and on site testing.

The workshop was such a success Shanghai NAPU Compressor Co. Ltd. was then founded in 2012.

NAPU Compressor is compliant with ISO 8573-1, Class 0 standard and audited by TUV Rheinland and China National Quality Inspection Center of Compressor and Refrigerator.

The company is also compliant with ISO 9001:14001 and is well-known in the domestic market for its quality-driven culture. The oil-free compressors manufactured by the company are used in a variety of sectors including some of our valued clients like CASC-China Aerospace Science Corporation, NORINCO-China North Industries Group, CNNC-China National Nuclear Group, CHANG AN AUTO, SINO-PHARM, BYD and CALT and Sino-Chemical etc.

Continuous improvement in productivity and efficiency is our goal, and we continue to offer an extensive services including our own branded oil-free compressor package as well as after-sales services for other leading brands.

NAPU[®]



CLASS 0
ISO 8573-1 certification



**OIL-FREE ROTARY SCREW
COMPRESSORS**

Shanghai NAPU Compressor Technology Co. Ltd.

 No.3238 Huhang Highway, Fengxian District, Shanghai, China  napucompressor.com
 info@napucompressor.com  021 - 58387871 13701958840

100% CERTIFIED OIL-FREE AIR

NAPU is renowned for designing and manufacturing some of the most durable oil-free screw compressors. The OFW/OFA high-end rotary screw compressor comes out of this strong tradition. Ideal for industries where high-quality oil-free air is key, the OFW/OFA offers the highest reliability and safety in combination with low energy costs.



CLASS 0
ISO 8573-1 certification



Oil free air compressor is used in a range of industries where air quality is critical to end products and production processes include food and beverage, pharmaceutical, chemical and petrochemical, semiconductor and electronics, the medical sector, automotive paint spraying, textile etc . In these critical environments, contamination by even the smallest quantities of oil can result in costly production suspended and contamination spoilage.

Food & beverage

- 100% pure, clean, oil-free air for all kinds of applications(e.g. fermentation, packaging, aeration, transportation, filling & capping, cleaning, instrument air).
- ISO 8573-1 CLASS 0 (2010) certification to avoid compromising the purity of your end product and ensure zero risk of contamination.

Textiles

- Easy and quick installation.
- A completely, fully integrated, ready-to-use solution.

Petrochemical

- Years of experience in providing compressed air for the oil & gas industry.
- 100% oil-free compressed air for control/instrument air or buffer air.
- Strong global support network to provide 24/7 assistance.

Pharmaceutical

- Ideal for applications such as flue gas desulphurization, oxidation air, and fluidized beds.
- Zero risk, maintain high quality standard and professional brand reputation

CLASS	oil content(paticles, liquid, vapor) mg/m ³
0	As specified by the equipment user or supplier and more stringent than class 1
1	<0.01
2	<0.1
3	<1
4	<5

Current ISO 8573-1 (2010) classes (the five main classes and the associated maximum concentration in total oil content).

Oil Free Air Technology

In the past 10 years, NAPU has invest majority business resources to develop oil-free air technology, resulting in a range of air compressors and blowers that provide 100% pure, clean air.

Through continuous research and development, NAPU achieved a new milestone, setting the standard for air purity as the first manufacturer to be awarded CLASS 0 certification.

Eliminating any risk

As the industry leader committed to meeting the needs of the most demanding customers, Atlas Copco request- ed the renowned TÜV institute to type-test its range of oil-free compressors and blowers. Using the most rigor- ous testing methodologies available, all possible oil forms were measured across a range of temperatures and pressures. The TÜV found no traces of oil at all in the output air stream.



Air Ends

- The unique profile design ensures the working efficiency and sealing of the compression
- Aviation type impeller coating ensures high durability
- The rotor section is made of high tensile, strength steel
- Cooling jackets is used for complete air end
- Seals are made of reusable high-quality alloys



Cooler

- Integrated design, compact and robust
- Spiral design of water flow, high heat exchange efficiency
- Easy to switch with integrated heat recovery module
- Built-in flow channel, simple and reliable

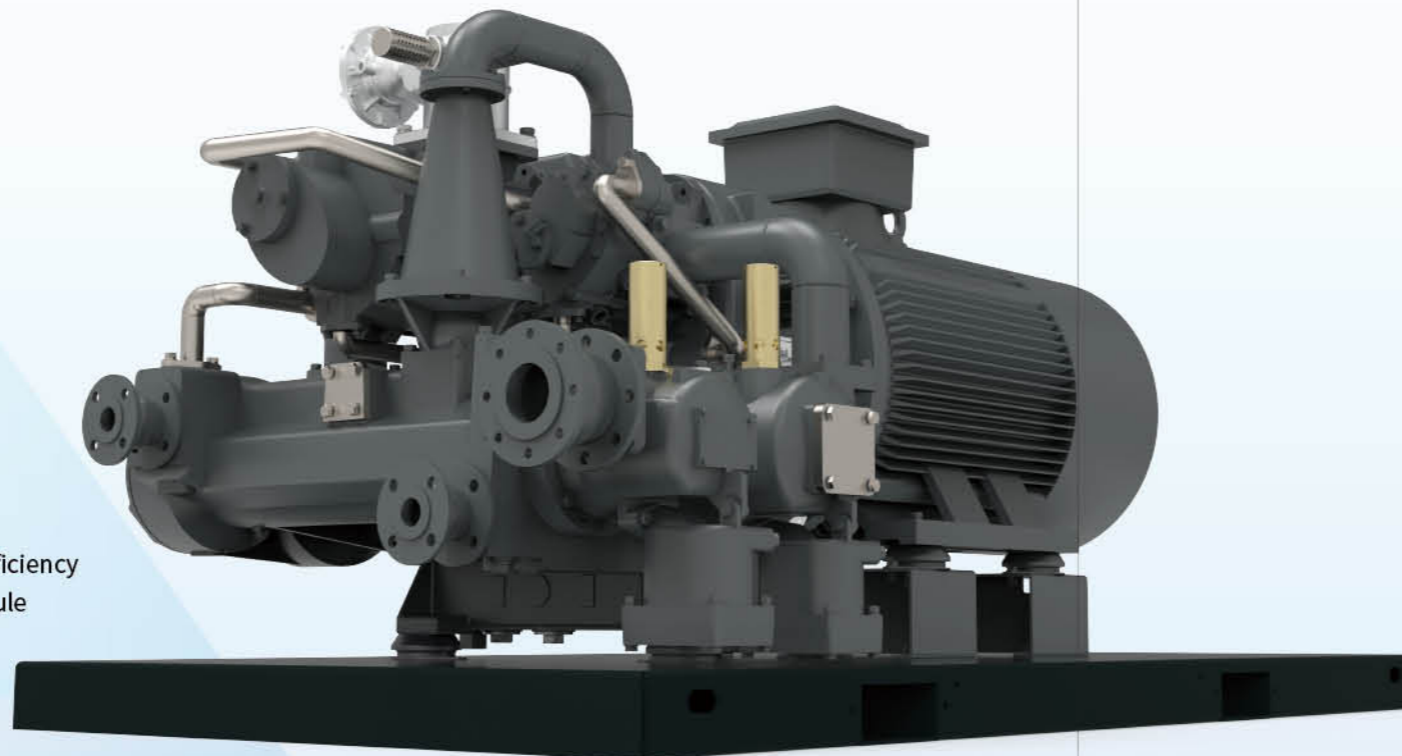

Airflow Duct

- All cast iron material, inner wall coating, optimal noise reduction design.
- High pressure outlet cast iron three-in-one integrated design with venturi, exhaust and discharge channels.
- Exhaust muffler made of cast iron, integrated design, built-in muffler material and check valve.
- Full flange connection, reliable sealing and quick maintenance.



High Efficiency Cooler and Water Separator

- Corrosion-resistant material, long shell life
- Advanced welding procedure ensures reliable sealing.
- Star shaped fin design increasing the heat exchange area
- Labyrinth water separator effectively separates the condensed water



Electrical Motor

- High-end international brand motors and electrical components
- Industry's highest safety and efficiency standards



High Efficiency Oil-Free Compressor Aired

- The unique profile design ensures the working efficiency and sealing.
- Aviation type impeller coating ensures high durability
- The rotor section is made of high tensile, strength steel
- Cooling jackets is used for complete air end



Air Ends

- The unique profile design ensures the working efficiency and sealing of the compression
- Aviation type impeller coating ensures high durability
- Integrated oil tank and speed increasing gearbox
- Built-in high efficiency and reliability oil pump



Variable Speed Drive (VSD)

- Controller with fully integrated frequency converter and control panel
- Specially selected drive components parameterized precisely for maximum efficiency
- No blowing is required when the air demand does not reach the maximum value
- Optimized parts selection
- Reduce installation costs



Rotor Screw

- Corrosion-resistant material, long life
- Precise machining, rotor cutting grinding before measuring
- Coating PTFE fits working condition oil free
- High efficiency compressing

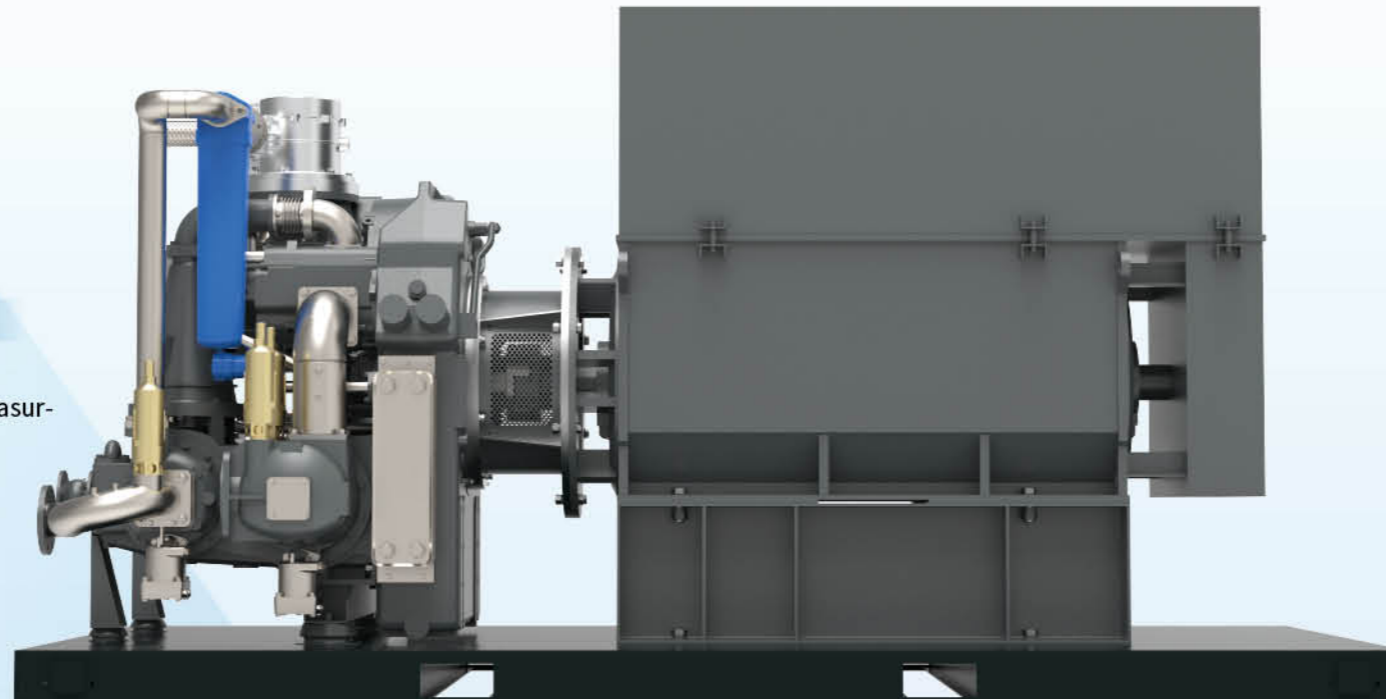

High-Efficiency Cooler Combination

- Compact design
- Integrated stainless steel pre-cooler and fin type after-cooler which is suitable for a wide temperature range and high efficiency
- Air flow distribution of hot and cold spaces improve heat exchange efficiency and noise reduction

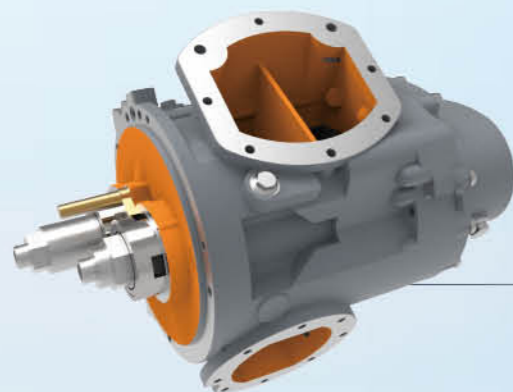

High Efficiency Oil Free Compressor Aired

- The unique profile design ensures the working efficiency and sealing of the compression
- Aviation type impeller coating ensures high durability
- The rotor section is made of high tensile, strength steel
- Cooling jackets is used for complete air end



Air Filter

- High quality intake filters provide reliable and high filtration.
- long lasting and lengthen the maintenance's interval

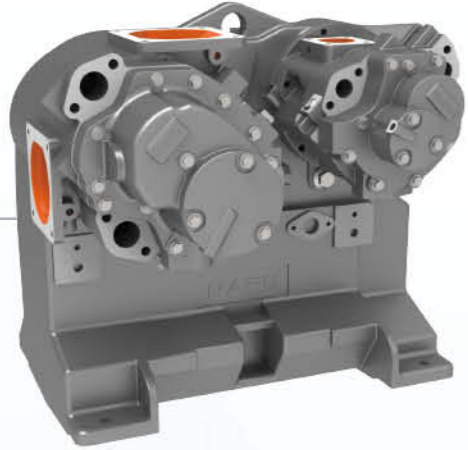

Air Ends

- The unique profile design ensures the working efficiency and sealing of the compression
- Aviation type impeller coating ensures high durability
- Built-in high efficiency and reliability oil pump



Load/Unload Oil Intake Valve

- Fully pneumatic, clean and safety
- High reliability integrated safety valve and relief valve functions
- Modular design, compact and responsive



i Dynamic

- Controls the main drive motor and regulates system pressure to maximize energy efficiency.

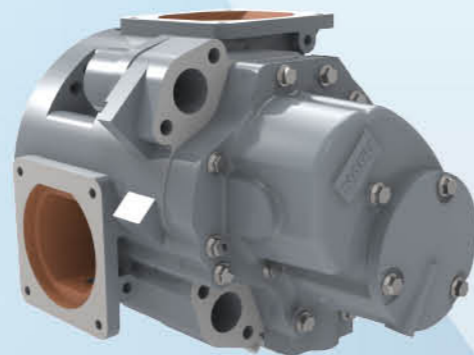

High Efficiency Oil-Free Compressor Airend

- The unique profile design ensures the working efficiency and sealing.
- Aviation type impeller coating ensures high durability
- The rotor section is made of high tensile, strength steel
- Cooling jackets is used for complete air end



Casing

- Casing design supports both water or oil cooling jackets
- Sufficient clearance of the moving parts when control temperature increase
- Efficient in reducing noise level

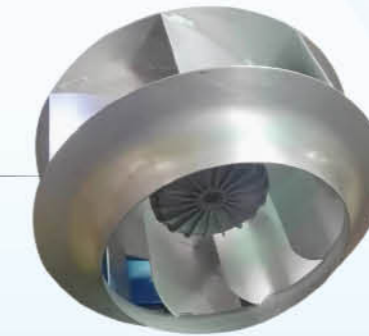

Centrifugal Fan

- Compact design with large air volume and higher air pressure
- High energy and low consumption.
- Low noise level and maintenance free

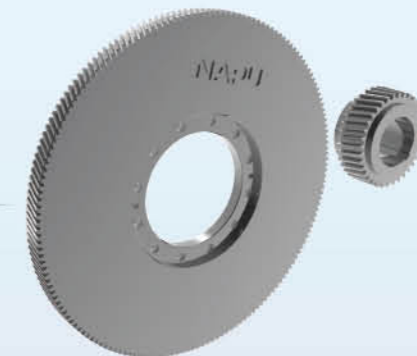

Gear Set

- DIN/AGMAQB manufacturing standard
- Efficient and robust, designed for 30 years of use
- Low vibration, low noise level



power frequency

Model	Nominal Flow Rate (M ³ /min)			Install Power (kw)	Noise Level (db)	Weight (KG)	
	7bar	8.5bar	10bar			Water Cooled Type	Air Cooled Type
OFA15	2.4	2.1	1.8	15	74	-	1 030
OFA22	3.7	3.2	2.7	22	74	-	1 070
OFA30	4.8	4.4	4.0	30	74	-	1 300
OFA37	5.9	5.3	5.0	37	74	-	1 355
OFA45	7.0	6.5	6.1	45	74	-	1 390
OFA55	9.2	7.9	7.3	55	74	-	1 860
OFA75	12.2	11.2	10.7	75	74	-	1 935
OFA90	14.7	13.5	12.7	90	74	-	2 000
OFA110	19.3	17.2	16.0	110	74	-	3 660
OFA132	22.9	19.5	18.8	132	74	-	3 700
OFA160	29.4	25.7	23.8	160	74	-	4 150
OFA200	36.6	33.1	30.4	200	74	-	4 230
OFA250	44.5	41.0	37.4	250	74	-	4 300
OFA275	47.4	43.0	41.0	275	74	-	4 500
OFA315	51.5	47.6	46.0	315	74	-	6 200
OFA355	56.3	52.6	50.4	355	74	-	6 500
OFW37	5.9	5.3	5.0	37	74	1 355	-
OFW45	7.0	6.5	6.1	45	74	1 450	-
OFW55	8.8	7.9	7.3	55	74	1 800	-
OFW75	11.9	11.2	10.7	75	74	1 850	-
OFW90	14.3	13.5	12.7	90	74	1 925	-
OFW110	19.1	17.1	16.0	110	74	2 635	-
OFW132	21.9	19.6	18.9	132	74	2 760	-
OFW160	28.3	26.1	24.2	160	74	3 850	-
OFW200	36.1	33.1	30.4	200	74	4 000	-
OFW250	43.1	41.0	37.0	250	74	4 100	-
OFW275	46.4	43.0	41.0	275	74	4 300	-
OFW315	50.9	47.6	46.0	315	74	6 550	-
OFW355	56.3	52.6	50.4	355	74	6 950	-
OFW400	62.1	57.8	55.8	400	74	7 050	-
OFW450	76.5	71.5	63.8	450	74	8 400	-
OFW500	83.9	78.3	73.1	500	74	8 400	-
OFW630	102.9	95.7	89.0	630	74	9 125	-
OFW750	122.8	109.6	101.8	750	74	9 225	-

frequency conversion

Model	Nominal Flow Rate (M ³ /min)	Install Power (kw)	Noise Level (db)	Weight (KG)	
				Water Cooled Type	Air Cooled Type
OFA15VSD	1.1 – 3.3	15	74	-	930
OFA22VSD	4.5 – 5.6	22	74	-	1 150
OFA30VSD	4 – 6.6	30	74	-	1 300
OFA37VSD	5 – 8.4	37	74	-	1 600
OFA45VSD	6.1 – 11.1	45	74	-	1 750
OFA55VSD	7.3 – 9.4	55	74	-	1 900
OFA75VSD	10.7 – 12.4	75	74	-	2 630
OFA90VSD	12.7 – 15.4	90	74	-	2 700
OFA110VSD	16.0 – 19.5	110	74	-	3 750
OFA132VSD	18.8 – 21.8	132	74	-	4 300
OFA160VSD	24.0 – 29.6	160	74	-	4 700
OFA200VSD	12.2 – 36.6	200	74	-	5 600
OFA250VSD	14.2 – 41.8	250	74	-	5 850
OFA275VSD	15.8 – 47.4	275	74	-	6 350
OFA315VSD	45.0 – 52.1	315	74	-	6 750
OFA355VSD	50.4 – 57.5	355	74	-	6 950
OFW37VSD	2 – 5.9	37	74	1 750	-
OFW45VSD	2.3 – 7	45	74	1 950	-
OFW55VSD	4.5 – 8.8	55	74	2 080	-
OFW75VSD	4.5 – 13.2	75	74	2 170	-
OFW90VSD	4.5 – 15.5	90	74	2 220	-
OFW110VSD	6.4 – 19.1	110	74	2 700	-
OFW132VSD	7.7 – 22.4	132	74	3 500	-
OFW160VSD	14.5 – 42.9	160	74	3 750	-
OFW200VSD	15.2 – 36.1	200	74	4 150	-
OFW250VSD	16.3 – 43.5	250	74	4 850	-
OFW275VSD	16.3 – 46.4	275	74	5 400	-
OFW315VSD	17.6 – 50.9	315	74	6 650	-
OFW355VSD	18.9 – 56.3	355	74	6 950	-
OFW400VSD	19.3 – 62.1	400	74	7 060	-
OFW450VSD	25.7 – 76.5	450	74	8 400	-
OFW500VSD	28.5 – 83.9	500	74	8 400	-
OFW630VSD	33.6 – 102.9	630	74	9 125	-
OFW750VSD	42.4 – 122.8	750	74	9 225	-